

## Manual for OGMA AP08CC, AP26CC and AP26MC cooled DSO cameras

### Manual for OGMA AP08CC, AP26CC & AP26MC

Learn how to use [AP08CC](#), [AP26CC](#), and [AP26MC](#) with help from our engineers and community.

This manual combines and covers features across the entire AP series. However, there are some differences between the different models within the same series. When a feature is not supported by a particular camera model, the associated control will either not appear in the managing software or be greyed out.

We don't print this manual for usability, cost, and environmental reasons. Specifically, we always want it to be up-to-date for you. We don't want it to increase the final price of your camera, and we don't want it to kill our planet's precious trees.

This living manual aggregates practical input submitted by users like you with input from our engineers. We believe you are the real expert and that our engineers are here to support you. This manual will evolve as a living document, so we recommend you bookmark this page and return to it often for fresh information.

The astronomy hobby thrives on collaboration and sharing knowledge for the entire community's benefit. Your input helps us improve and ensures we can provide the best possible experience for everyone.

Please [ask questions](#), [submit additions](#), and [suggest edits anytime!](#)

## Introduction

What makes a great astrophotography camera is not just the ultrasensitive photographic sensor inside, but rather how each component is selected and ensambled in order to convert every photon that arrives from a distant object into a usable digital image.

We, at OGMAVision, are pleased to bring to you various astrophotography cameras that, without breaking the bank, will often perform better than comparable models from leading brands. We have achieved this level of quality by using only componetes that are best in class, by carefully testing every part that it is added into a camera, and by working with a proprietary firmware that makes the best use from every component inside the camera.

We love astrophotography and we know how precious are the hours that you'll spent imaging with your gear. We take pride on all our products and we hope that you will enjoy using them as much as we do.

## OGMA AP26CC and AP26MC

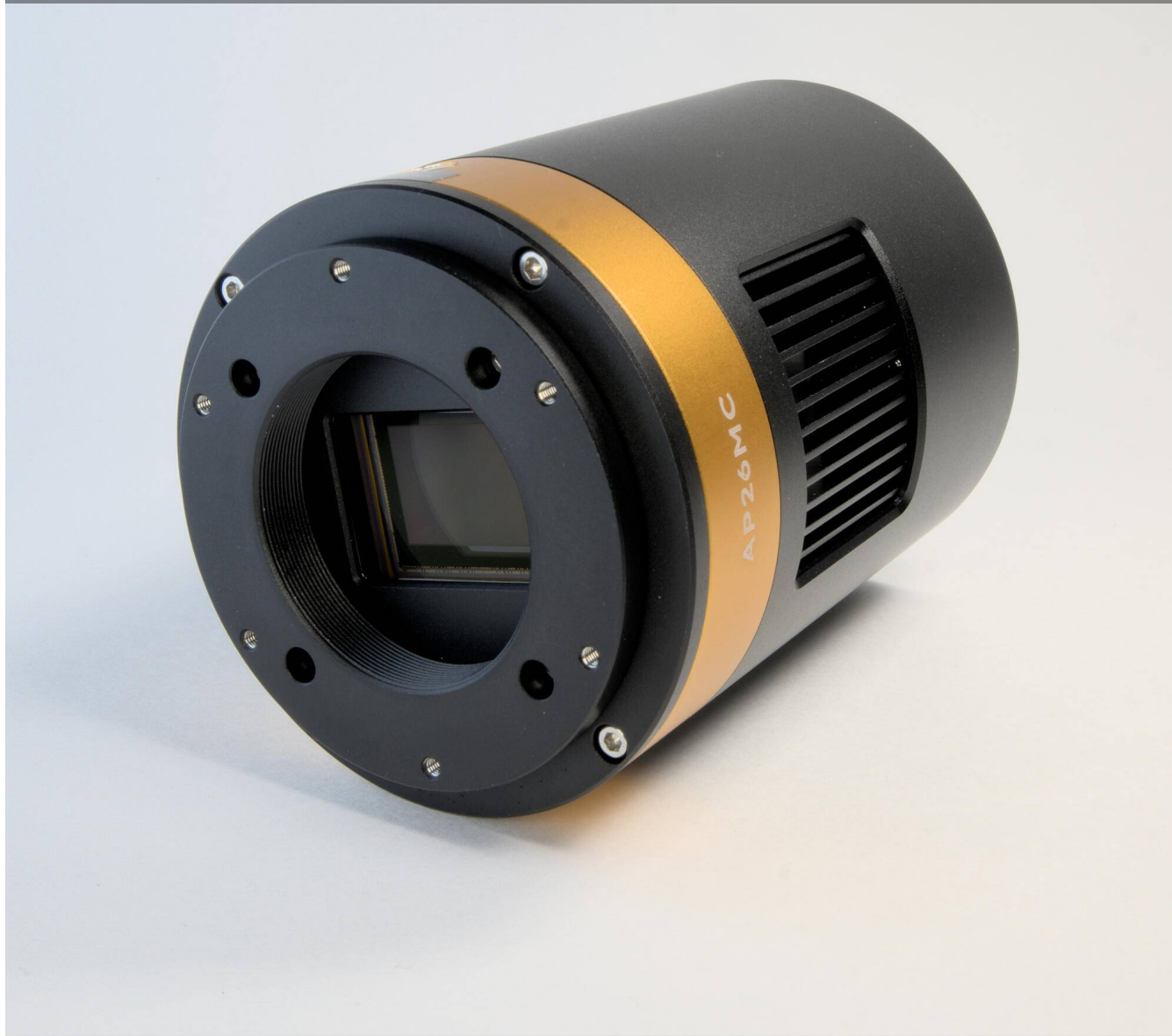

This is the user's manual for the OGMA [AP26CC](#) and [AP26MC](#), two versatile cameras designed with a variety of applications in mind. The three most important characteristics of these two cameras are:

- Cooled CMOS sensor
- Ultra-low readout noise
- Zero amp-glow

All the above in addition to other features that we discuss in this manual, are making the OGMA [AP26CC](#) and [AP26MC](#) ideal for scientific and industrial photographic applications that include deep sky astrophotography, planetary astrophotography, and microscopy.

## How to read our model numbers

The OGMA AP26CC and AP26MC models are very similar; their main difference is that the AP26CC uses a color sensor while the AP26MC uses a monochrome sensor.

You can read these two model numbers as follows:

**AP** = Main use, in this case Astrophotography

**26** = Number of megapixels, in this case 26Megapixels

**M** or **C** = Indicates whether the camera sensor is Monochrome or Color

**C** = The last character indicates whether the camera sensor is cooled or not



## Main features of AP26CC & AP26MC

The versatile OGMA AP26CC and AP26MC cameras have been designed mainly for deep sky astrophotography; however, since they have cooled CMOS sensors, ultra-low readout noise, and zero amp-glow, they are also good for planetary astrophotography and microscopy.

The main features of OGMA AP26CC and AP26MC are listed below:

**Sensor:** Sony IMX571 CMOS Sensor (Color or Monochrome, depending on camera model)

**Resolution:** 6224 x 4168 pixels

**Mega Pixels:** 26MP

**Pixel size:** 3.76  $\mu\text{m}$  (square pixels)

**Format:** APS-C

**Amp-Glow:** Zero Amp-Glow

**Data Interface:** USB3.0/USB2.0

**USB Hub:** 2 ports to share the USB connection

**DDR3 Buffer:** 512MB (4Gbit) sufficient for reliable data transfer over USB3.0 (1Byte = 8bit)

**Full-well:** 100Ke-

**Cooling:** 40°C below ambient

## SharpCap Sensor Analysis (AP Series)



The SharpCap sensor analysis is a popular test used by amateur astrophotographers to evaluate the performance of their cameras.

### How did we conduct the SharpCap Sensor Analysis?

We connected the camera to a Windows laptop using a USB 3.0 port on the laptop.

In SharpCap, we selected the [OGMA ASCOM driver](#) to connect to the camera.

Note that we didn't use the DirectShow driver because the USB transfer speed is slower with DirectShow.

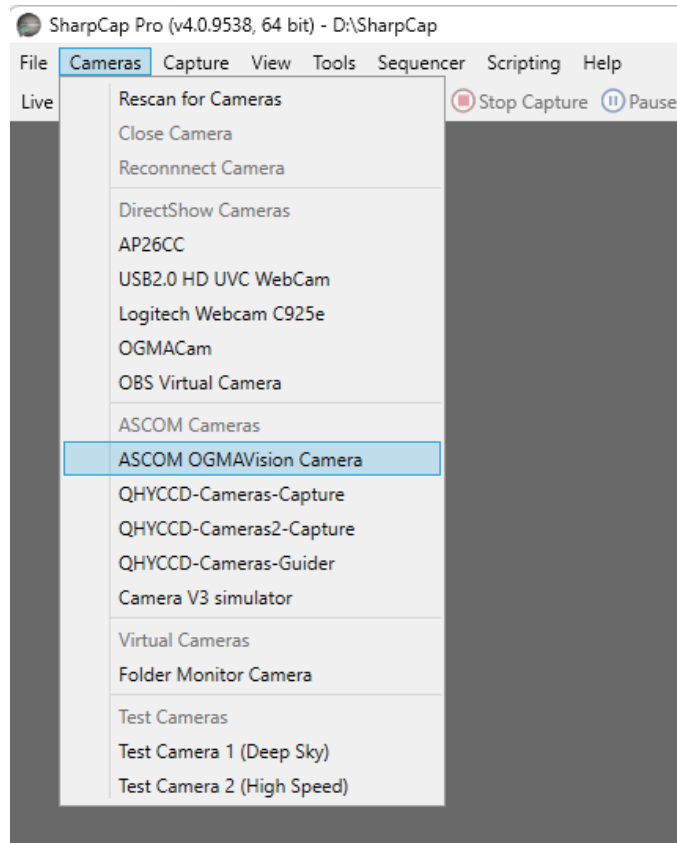

We ran two sensor analyses: one for High Conversion Gain (HCG) and another for Low Conversion Gain (LCG).

We configured the ASCOM connection for 16 bits, Raw format, Low Noise, and High Fullwell Capacity.

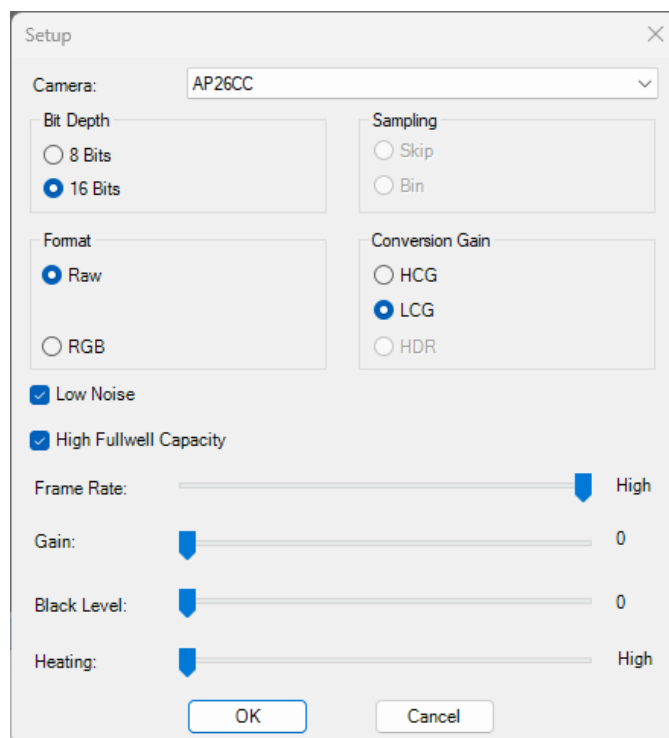

## See the Analysis Charts

You can see the actual result of our analysis for each cooled camera on their respective product pages. Look for the interactive graphs near the bottom of the page:

- [AP08CC](#)

- AP26CC
- AP26MC

## What to Look For?

The performance of a digital camera can be evaluated using the following four parameters:

- **e-/ADU**

The sensors found in cameras used for vision applications have pixels that convert incoming photons into electrons. Gain on a CCD /CMOS camera represents the conversion factor from electrons (e-) into digital counts, or Analog-Digital Units (ADUs). Gain is expressed as the number of electrons that get converted into a digital number, or electrons per ADU (e-/ADU).

- **Read Noise**

Read Noise is the most important reference for measuring a digital camera's performance. Lower read noise usually means better signal-to-noise Ratio (SNR) and better image quality. Read Noise is created within the camera electronics during the readout process as the electrons are subjected to the analog-to-digital conversion, amplification, and processing steps that enable an image to be produced.

- **Full Well**

The electrons are held in each pixel and are converted into electrical charge, which can be measured to show the amount of light that has fallen on each pixel. The maximum electrical charge possible is termed "full well capacity". Under the same conditions, such as noise and A/D converter quality, the greater the full well capacity a sensor has, the wider the sensor's dynamic range. As there is a limit to the depth to which pixels can be made, the full well capacity is often proportional to the frontal area of the light-gathering element of the pixel.

- **Dynamic Range**

It is the ratio between the maximum output signal level and the noise floor at minimum signal amplification (noise floor, which is the RMS (root mean square) noise level in a black image). The noise floor of the camera contains sensor readout noise, camera processing noise, and the dark current shot noise. The dynamic range represents the camera's ability to display/reproduce the brightest and darkest portions of the image and the number of variations between them. This is technically an intra-scene dynamic range. Within one image, there may be a portion that is completely black and completely saturated.

## Analysis Charts (AP Series)

### Important Disclaimers:

1. Different manufacturers may use different Gain scales; therefore, using a particular Gain number to compare different camera models may be meaningless. Instead, consider the values registered at each end and the Gain range to understand your camera's capabilities better.
2. The SharpCap sensor analysis can offer different results within the same camera model. You may see variations after running the same analysis on the same camera. Therefore, some differences are expected between our measurements and yours.

## Where are the charts?

You can see the charts from our SharpCap analysis of each camera on their respective product pages:

- [AP08CC](#)
- [AP26CC](#)
- [AP26MC](#)

Look for the interactive graphs near the bottom of the page.

## Technical Specs of AP26CC & AP26MC

<b>Camera Type</b>	Digital still image	
<b>Sensor</b>	Sony IMX571 back illuminated sensor (Color or Monochrome depending on model)	
<b>Diagonal</b>	28.3 mm	
<b>Image Resolution</b>	26 mega pixels (6224x4168)	
<b>Pixel Size</b>	3.76µm x 3.76µm	
<b>Image Area</b>	23.4mm x 15.7mm	
<b>Max FPS at Resolution</b>	<b>16bit</b>	<b>8bit</b>
	6.8 FPS @ 6224x4168 28 FPS @ 3104x2084 63 FPS @ 2064x1386	13.2 FPS @ 6224x4168 37.1 FPS @ 3104x2084 110 FPS @ 2064x1386
<b>Max FPS at Resolution (Low Noise)</b>	<b>16bit</b>	<b>8bit</b>
	3.4 FPS @ 6224x4168 (Low Noise Mode is only available in All Pixel Readout Mode)	12.7 FPS @ 6224x4168 (Low Noise Mode is only available in All Pixel Readout Mode)

<b>Shutter Type</b>	Rolling shutter
<b>Exposure Time</b>	0.1ms - 3600s
<b>Gain</b>	1x - 100x
<b>SNR</b>	47.1 dB
<b>Dynamic Range</b>	86.8 dB (Low Noise Mode)
<b>Read Noise (LCG)</b>	1.48 - 3.23 e-
<b>Read Noise (HCG)</b>	1.32 - 0.82 e-
<b>QE Peak</b>	>80%
<b>Full Well</b>	100ke-
<b>ADC</b>	16bit
<b>DDR3 Buffer</b>	512MB (4Gbit) sufficient for reliable data transfer over USB3.0 (1Byte = 8bit)
<b>Data Connection Port</b>	USB3.0/USB2.0
<b>Data Hub</b>	2 USB ports
<b>Optical Path Connection</b>	<p>M42 x 0.75mm</p> <p>Also, six M2.5 holes matching popular models of filter wheels and OAGs (requires M2.5 screws)</p> <p>See <a href="#">optical path connections</a></p>
<b>Protective Window</b>	Double-side coating protective Anti-Reflections (AR) glass



<b>Spectral Range</b>	350-1050nm
<b>Recording System</b>	Still picture and movie
<b>Camera Dimensions</b>	Diameter 80mm x height 103mm
<b>Camera Weight</b>	0.552kg
<b>Back Focus Distance</b>	17.5mm
<b>Cooling:</b>	Two stage TEC
<b>Effective Cooling Temperature:</b>	-35°C below ambient under short exposure/ -40°C under long exposure(> 1s)
<b>Operating Temperature:</b>	-5°C to 50°C
<b>Storage Temperature:</b>	-10°C to 60°C
<b>Operating Relative Humidity:</b>	0 to 80%
<b>Supported OS</b>	Microsoft® 10 / 11 (32 & 64 bit) OSx(Mac OS X) Linux MacOS
<b>Operating Voltage</b>	12V DC power adapter supplied Acceptable range for batteries: 11-14V DC 5.5 x 2.1mm plug diameter Center positive plug

Please note that some parameters listed in the product specification tables of this website may undergo modifications as part of our continuous efforts to enhance the product's overall performance, usually through firmware updates. We assure you that when changes are made, it is to maximize the product's capabilities and enhance the user experience.

## Analogic Digital Conversion and Region of Interest

The OGMA AP26CC and AP26MC cameras have a 16bit Analog Digital Conversion (ADC). It also have a 12bit output mode for hardware binning and smaller resolution.

Higher ADC allows capturing more tonal values, deeper shadows and smoother gradients.

Particularly interesting to those who are doing planetary imaging and lucky imaging, the AP26CC and AP26MC cameras also support Region of Interest (ROI) at the hardware level. When the user selects a ROI, the camera only has to transmit data from a partial region of a sensor allowing the output of data at a higher framerate. The smaller the ROI size is, the higher the frame rate will be.

### Frames per second (FPS) of the OGMA AP26CC and AP26MC in 16/8bit mode, USB3.0 / USB2.0 data transfer interface at different resolutions

Resolution	16bit ADC		8bit ADC	
	FPS on USB3.0	FPS on USB2.0	FPS on USB3.0	FPS on USB2.0
6224x4168	6.8	0.6	14.2	1.2
6224x4168 (Low Noise)	3.4	0.3	NA	NA
3104x2084	28	3.6	37.1	7.0
2064x1386	63	8.5	110	15.7

## Bayer Pattern of the Color Sensor

The bayer pattern of the OGMA color camera is "RGGB". Monochrome cameras don't use a Bayer pattern.

In most cases, the Bayer pattern of the color sensor will be automatically detected by the driver used to connect to the camera.

When in doubt, select the "RGGB" bayer pattern.

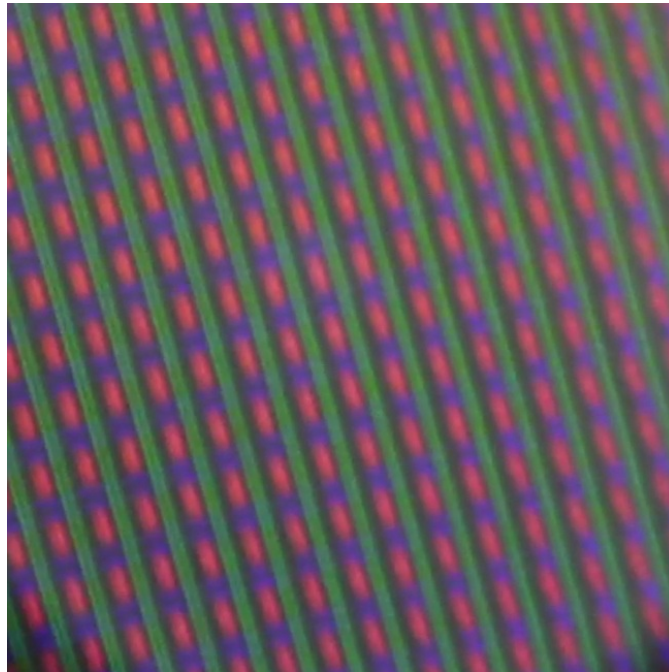

## **Binning**

In digital photography, binning is a process by which multiple nearby pixels are combined into a larger pixel. Binning improves the signal-to-noise ratio at the expense of a lower resolution image.

The OGMA AP26CC and AP26MC cameras support digital binning from 1x1 to 8x8 in either stacking or averaging method, and hardware binning from 1x1 to 3x3 in averaging method.

Hardware pixel binning is much faster than software binning.

## **DDR3 Buffer**

OGMA AP26CC and AP26MC cameras have a 512MB (4Gb) DDR3 buffer, which helps maintain the stability of data transmission, and effectively reduce the amp-glow caused because image data can be temporarily buffered without being sent hastily to the receiver.

## **Sensor Cooling System**

The cooling system of OGMA AP26CC and AP26MC is a two-stage Thermoelectric Cooler (TEC) with controllable electric fan to assisting heat dissipation.

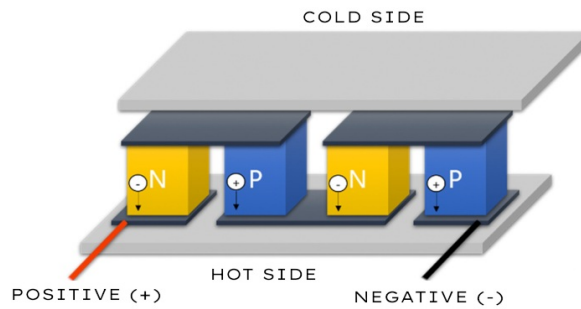

The TEC system is controlled by a PID algorithm, which allows the TEC to be precisely regulated towards the target temperature with 0.1°C deviation. Such efficient cooling system guarantees the stability of ultra-low noise mode and quality of the camera image.

The effective temperature reduction can be -35°C from ambient temperature. This means that if the environment temperature is 10°C, you could lower the temperature of the sensor to -25°C.

Some people prefer cooling the sensor as much as possible. We recommend cooling the sensor to a working temperature between 0°C and -10°C because below this temperature there is a diminished return on noise reduction for each additional degree of temperature reduction. Also because by not cooling to the extreme, you will be reducing the thermal stress on the sensor which will extend the useful life of your camera.

## Zero Amp-Glow

The cameras OGMA AP26CC and OGMA AP26MC have been carefully designed to provide images that are free of amp-glow. The following image shows two dark frames taken by two different cameras at 20°C on a 5-minute exposure time.

Previous generation of cameras produced an amp-glow that inevitably affected the quality of the images and had to be corrected in postprocessing using dark frames.

Images captured by OGMA AP26CC and AP26MC will have zero amp-glow.



[Download a sample unprocessed dark frame](#) taken with the OGMA AP26CC camera at room temperature.

**Note:** We used room temperature in this test to try to spot any possible Amp-glow. At room temperature some noise is to be expected.

## Connections

There are three types of connections that you will have to set up before using the camera:

- [Optical path connection](#)  
These are the physical connections between the camera and the telescope, filter holders, electronic filter (EFW), off-axis guiders (OAG)
- [Back focus](#)  
Learn how to reach the proper back focus with any combination of equipment
- [Data connection](#)  
Needed to establish communication between the camera and the controlling computer.
- [Power connection](#)  
Needed to feed electricity to the camera.

## Optical Path Connections AP26 & AP08

The content of this section is in progress; you can contribute to improving it by [sharing your experience](#) with us.



There are two ways of connecting devices to the optical path of the AP26-series cameras:

### **The M42x0.75 interior thread**

This interior thread works well for attaching filter wheels, telescopes, filter holders, etc. If your device has a different diameter/thread, you may be able to use a thread adapter.

### **The six small holes with M2.5 threads**

These six holes are distributed over a circumference of 62mm of diameter line up. They have an internal thread, M2.5. These holes line up with the holes on the ZWO 2" EFW (or the holes on the "new" 36mm ZWO EFW). They also match the position of the holes of the QHY CFW-L, but you will have to purchase M2.5 screws because the screws provided by QHY are M3 thread.

The QHY filter wheels come with six screws that have an M3 thread. You can use a QHY filter wheel but must buy 6 (M2.5) screws. Amazon sells packs of different sizes. [McMaster-Carr sells them](#) very cheap. Also, you have to select the length that you need, probably 6 or 8 mm, depending on the thickness of the wall of the filter wheel. Again, buying different screws is only required for QHY filter wheels.

## Optical Path Connections AP24

The content of this section is in progress; you can contribute to improving it by [sharing your experience](#) with us.

There are two ways of connecting devices to the optical path of the AP24CC cameras:

### The M54x0.75 interior thread

This interior thread works well for attaching filter wheels, telescopes, filter holders, etc. If your device has a different diameter/thread, you may be able to use a thread adapter.

### The six small holes with M2.5 threads

These six holes are distributed over a circumference of 62mm of diameter line up. They have an internal thread, M2.5. These holes line up with the holes on the ZWO 2" EFW (or the holes on the "new" 36mm ZWO EFW). They also match the position of the holes of the QHY CFW-L, but you will have to purchase M2.5 screws because the screws provided by QHY are M3 thread.

The QHY filter wheels come with six screws that have an M3 thread. You can use a QHY filter wheel but must buy 6 (M2.5) screws. Amazon sells packs of different sizes. [McMaster-Carr sells them](#) very cheap. Also, you have to select the length that you need, probably 6 or 8 mm, depending on the thickness of the wall of the filter wheel. Again, buying different screws is only required for QHY filter wheels.

## Suggested Connections for 55mm of back focus

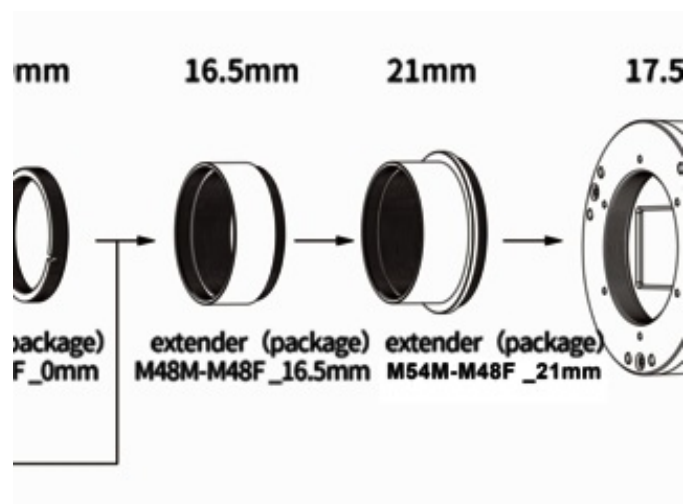

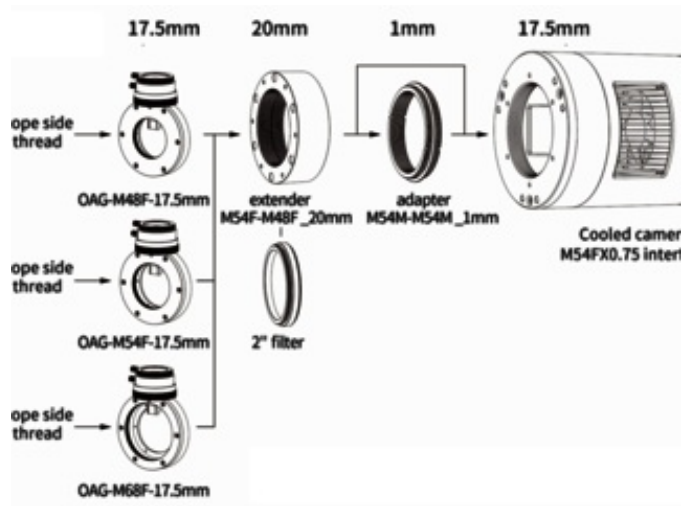

## AP08CC Mechanical Drawings

### AP08CC

All OGMA cooled cameras have similar dimensions, but the AP08 series has a smaller SONY IMX585 sensor.

Click to expand the mechanical drawings.

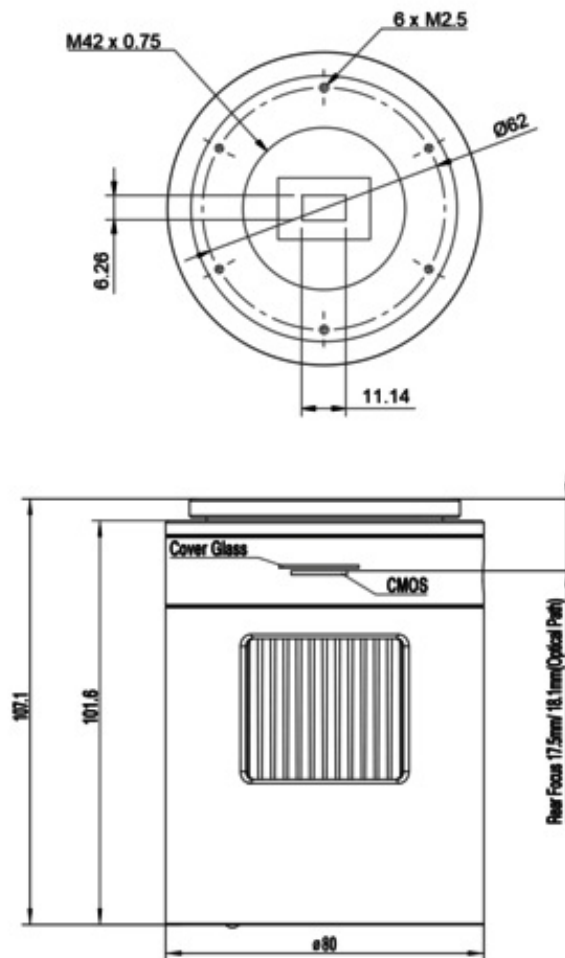

## Cooled Cameras

All OGMA cooled cameras have similar dimensions.

The drawings below are from the AP26 series, but they also apply to the AP08CC, with the only difference being that the AP26 series has a larger SONY IMX571 sensor, while the AP08CC has a smaller IMX585 sensor.

Click to expand the mechanical drawings.

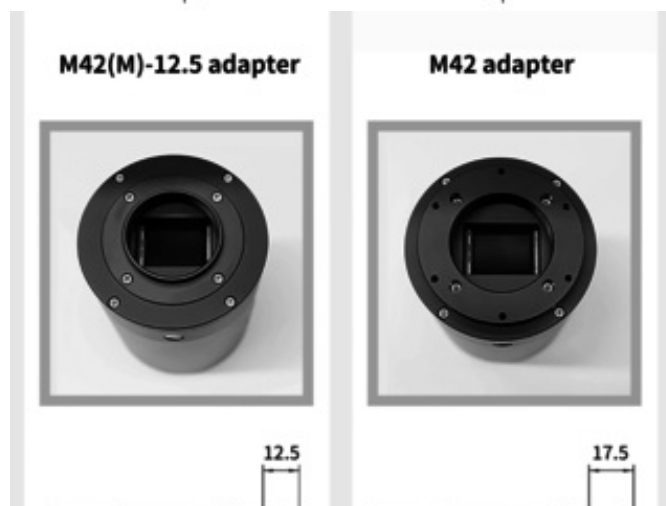
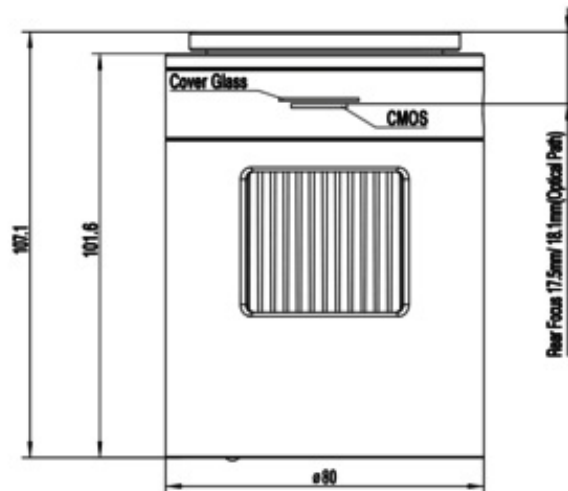
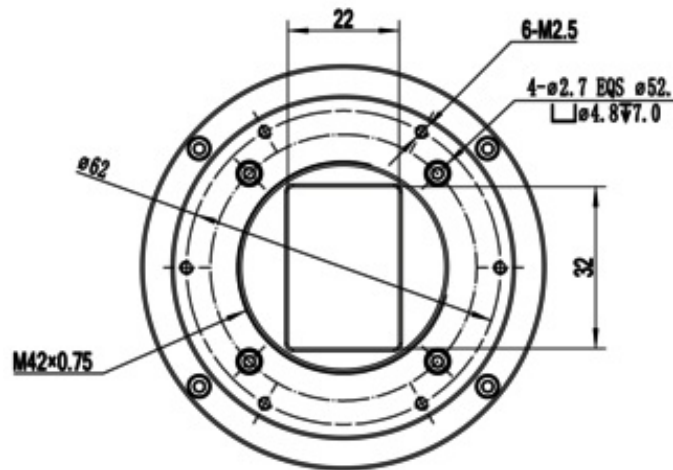



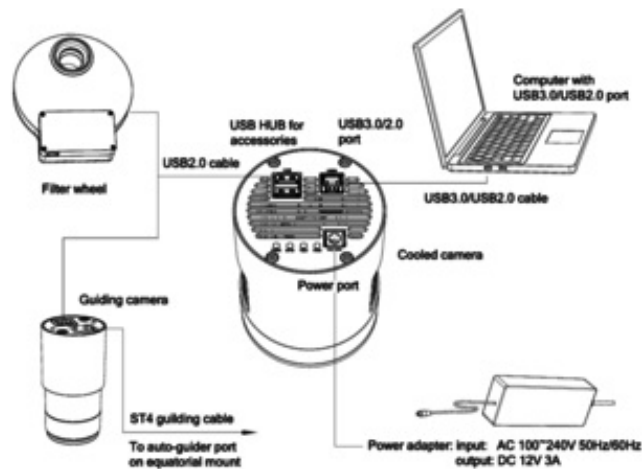
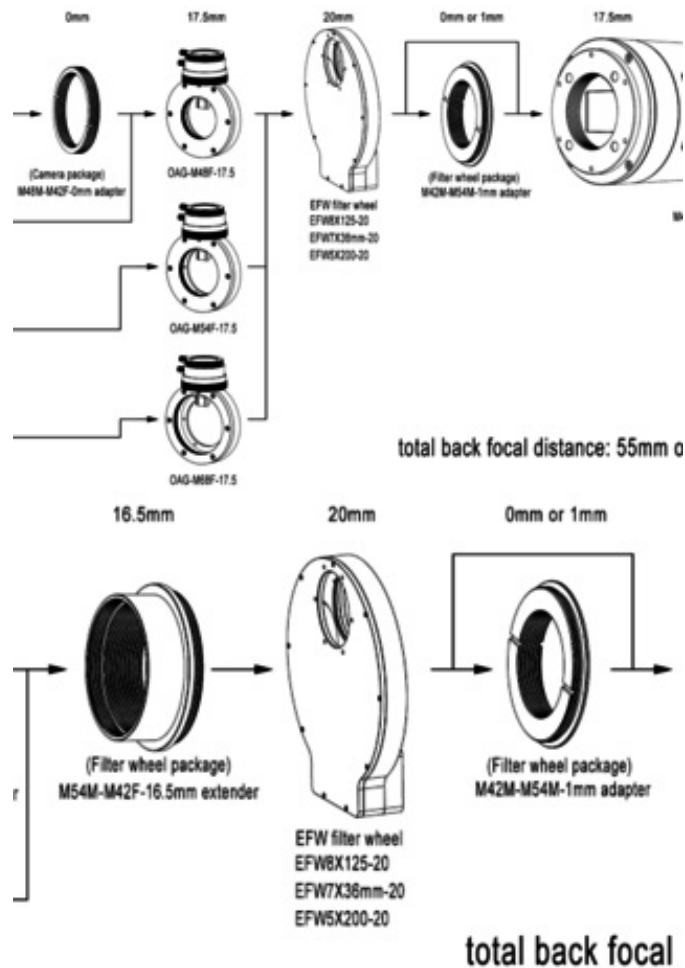

## Back Focus

**17.5mm is the contribution to back focus of the cameras AP26CC and AP26MC**

### Backfocus Theory

The back focus distance is actually a property set by the optics (i.e. the telescope, the focal reducer, field flattener, etc). The backfocus distance is the distance required by a particular optical element in order to project a focused image on top of a camera sensor. Everything that you put between the optics and the camera sensor, must add up to the total back focus distance required by the optics.

When you use a focal reducer or a field flattener, the backfocus distance that you need to achieve is often the number given by the manufacturer of the focal reducer or the field flattener that you are using.

In the case of the cameras OGMA AP26CC and AP26MC, the distance from the front face of the camera to the sensor is **17.5mm**. We refer to this parameter as the backfocus distance of the camera.

**For example**, in order to achieve proper focus with a telescope that requires 55mm of backfocus, you'll need to subtract 17.5mm from 55mm. The resulting 37.5mm is the distance that you have to put between the camera and the telescope. You can achieve this distance by combining filter holders, extension rings, adapters, filter wheels, OAGs, etc.

Since it is impossible for us to know what devices you own, we can't tell you exactly how you will achieve these 37.5mm (from the example above).

**If you are using a refractor telescope**, often the focuser will provide enough movement to reach the backfocus distance without the need to add other devices or spacers between the telescope and the camera.

**If you can't reach the backfocus distance by moving the focuser**, (this is often the case when using a focal reducer) you will have to look at the specifications of the elements that you plan to connect between the camera and the telescope and fill the gap with extension rings.

For example, [M48x0.75 extension rings from different brands can be found at Amazon](#). Depending on the diameter and thread on the back of your telescope, you may need different adapters or extension rings.

## Backfocus Formula

A formula to calculate how much extension rings you need to fill the gap to achieve the backfocus set by the optics is the following:

$$ER = BF_{opt} - BF_{cam} - BF_{other}$$

Where:

**ER:** Width of extension rings

**BF<sub>opt</sub>:** Backfocus distance required by the last optical element (i.e. the telescope, focal reducer, or field flattener)

**BF<sub>cam</sub>:** Backfocus distance of the camera

**BF<sub>other</sub>:** Backfocus distance of all other elements between the camera and the last optical element (i.e. filter holders, extension rings, adapters, filter wheels, OAGs, etc)

## Data Connection

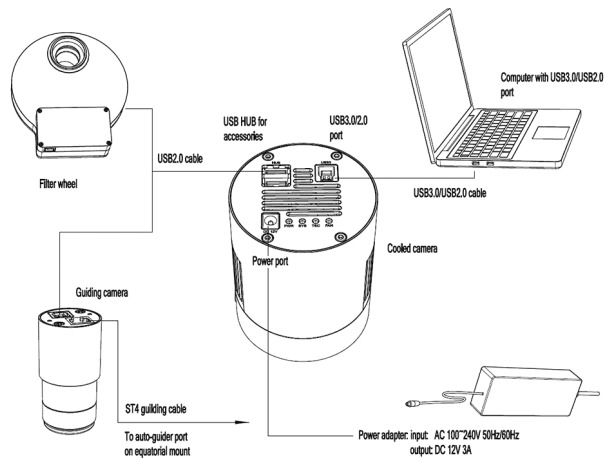

## Data Connections

Your OGMA camera has a fast USB 3.0 port on the back that you will use to connect the camera to a computer.

Even though the physical port is USB 3.0, the camera and the computer can communicate using either a data interface USB 3.0 or USB 2.0. The USB 2.0 data interface offers transfer rates of up to 480 Mbps and USB 3.0 offers transfer rates of up to 4.8 Gbps - that's 10 times faster.

To take advantage of the higher speeds of USB 3.0, make sure to plug the USB cable into a USB 3.0 port of the computer.



## USB 3.0 vs USB 2.0

USB 3.0 ports are usually blue while USB 2.0 ports are black.

If you connect your camera to a USB 2.0 port in your computer, you might experience slow connectivity, dropped frames, images with bands, etc.

The following image shows an ASCOM connection with a cable plugged into a USB 2.0 port.

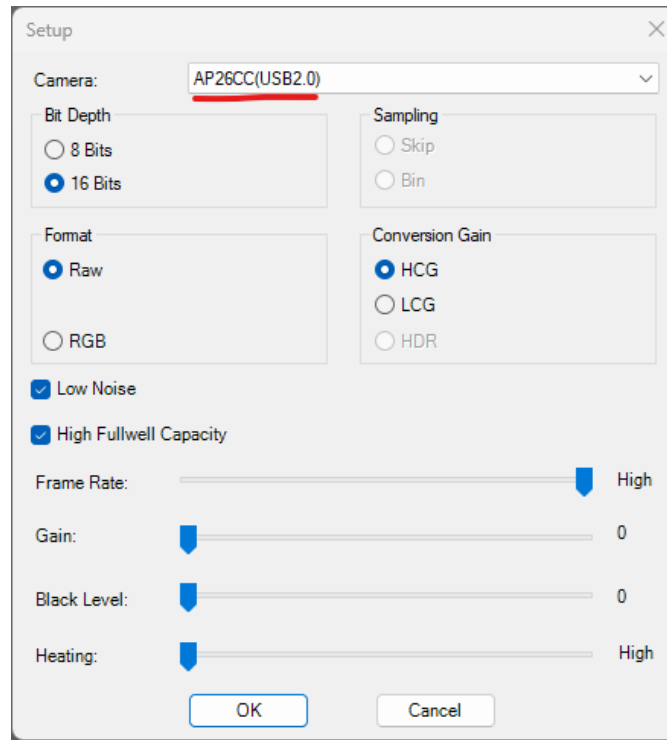

Once the cable is plugged into a USB 3.0 port, the ASCOM configuration dialog box will show as follows:

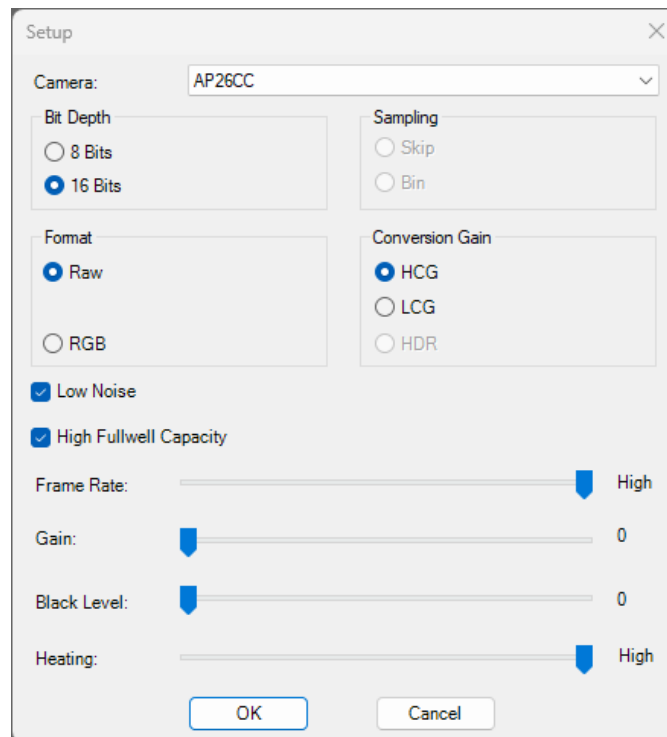

## USB Hub

Your camera comes with 2 USB 2.0 ports on the back that you can use to share the USB connection with other devices such as focuser, filter wheels, mounts, etc.

## Power Connection

## Voltage

## Voltage

The recommended power source is the 12V DC 3A power adapter supplied with the camera.

The physical dimensions of the power interface located on the back of the camera are 5.5 x 2.1mm.

When you are away from a residential power outlet, you may use a power bank or a battery that produces a DC voltage between 11V and 14V. Remember that a voltage below or above this range could damage your camera and void the warranty.

Note that some batteries sold as 12V could output a higher voltage when fully charged and a lower voltage when they are almost depleted. In general, it is recommended that you test your battery's actual voltage before connecting a camera.

## Power usage

Depending on your environment and configurations, the power requirements may be different.

To give you an idea, the power demand oscillates between 4 Watts and 24 Watts at room temperature with the TE cooler turned ON while the sensor cools down.

Here are some real-life measurements:

TE Cooling Power	Energy Demand (Watt)
60%	11
70%	14
82%	17
95%	23

We do not recommend using the camera with the TE cooler OFF because it can get very hot.

## USB 3.0 Connectivity

The camera comes with a physical USB 3.0 port for fast and reliable data transfers,

There is nothing new to say about using the USB 3.0 connection; it's just plug-and-play. However, it is important to mention a frustrating scenario we occasionally encounter that depends on external factors outside the camera.

We occasionally receive a support request mentioning that "***a camera is recognized as a USB 2.0 device instead of USB 3.0 on Windows***". This generally gets corrected after unplugging and plugging it again. This is not specific to our cameras; it can happen with any USB 3.0 device.

After helping multiple users troubleshoot the issue, we can tell that so far, the problem has been either a misconfiguration in Windows, a problem with the computer's physical USB port, or a bad USB cable.

To troubleshoot the issue of your camera being recognized as a USB 2.0 device instead of USB3.0 on Windows, follow these steps:

**1- Check the USB Port:** Ensure the camera is plugged into a USB 3.0 port on your computer. USB 3.0 ports are usually marked with a blue color inside the port or have "SS" (SuperSpeed) next to them.

**2- Verify Cable Quality:** Use a USB 3.0 cable, preferably the one we sent. A USB 2.0 cable will limit the connection to USB 2.0 speeds.

**3- Update USB Drivers:**

- Open Device Manager by right-clicking the Start button and selecting "Device Manager."
- Expand the "Universal Serial Bus Controllers" section.
- Right-click on each USB controller and select "Update driver."
- Choose "Search automatically for updated driver software" and follow any prompts to install updated drivers.

**4- BIOS/UEFI Settings:**

- Restart your computer and enter the BIOS/UEFI settings (usually by pressing a key like F2, Del, or Esc during boot-up).
- Check if there is an option to enable or configure USB 3.0 support and ensure it is enabled.
- Save changes and exit the BIOS/UEFI.

**5- Windows Update:**

- Go to Settings > Update & Security > Windows Update and check for updates.
- Install any available updates and restart your computer if necessary.

**6- Check Power Management Settings:**

- In Device Manager, right-click each USB Root Hub and select "Properties."
- Go to the "Power Management" tab and uncheck "Allow the computer to turn off this device to save power."
- Click "OK" to apply the changes.

**7- Use Different USB Port:**

- Try connecting the camera to a different USB 3.0 port on your computer. Sometimes, individual ports may have issues, or a contact may be damaged.

If these steps do not resolve the issue, there might be a hardware compatibility problem or a deeper issue with the USB 3.0 controller on your motherboard. In such cases, consulting your computer's technical support might be necessary.

## Settings

**Note:** This section is under development. Feel free to submit questions and recommendations using our [contact form](#).

Let's discuss some of the settings of OGMA AP26CC and AP26MC for astrophotography:

- [Recommended Settings](#) (to get you started)
- [Gain](#)

- [Conversion Gain Switch](#)
- [Bit Scaling & Bit Depth](#)
- [Ultra Mode & Low Noise](#)

You can follow the links above to learn more about each setting.

## Recommended Settings

It's hard to recommend the ideal settings of a camera because they depend on your particular conditions and the target that you are imaging. However, here are some pointers to help you get started:

- **Dew Heater**

Unless you live in an arid area, it's convenient to have it ON.

- **Target Dew Heater Strength**

Depending on your weather, keep it off if you live in a dry place. If you live in a humid area like Florida, raise it to 4, but remember that this will use a lot of power, and your camera will warm up. A value of 1 or 2 is acceptable in most cases.

- **Offset**

200 is a good starting point for most.

One of our customers calculated the ideal offset for their sky conditions on the AP08CC using bias frames in NINA and found the following:

HDR: gain 100, offset 1500

LCG: gain 100, offset 245 (preset 256)

HCG: gain 100, offset 450

- **Conversion Gain (HCG vs. LCG)**

It depends on your target and the trade-off between how much dynamic range you want and how long you can make your sub-exposures before getting elongated stars or star trails. You can start by using HCG and see how it feels.

If you want maximum dynamic range, excellent tracking, and the ability to spend much time on a target, try LCG.

- **Ultra mode or Low Noise**

ON is preferred because it provides a higher signal-to-noise ratio at the expense of a lower frame rate. However, it should be OFF if you are doing lucky imaging and need a higher frame rate.

- **High Fullwell Mode**

ON is nice.

- **Fan Speed**

This setting is only visible in some of the native camera integrations (e.g., NINA). It should always be 1 while the TE cooler is running.

- **Gain**

Use 100 if you have excellent tracking, your target is bright, and you want maximum dynamic range. However, if your target is dark, your tracking gives you elongated stars, and you have no way to improve them, then raise the gain to shorten the sub-exposures until the stars are round. Keep in mind that this will reduce your dynamic range, but you will still be able to get decent images.

- **Temperature**

We recommend cooling the sensor down to just 0 degrees Celsius because below this temperature, return is diminished, and you'll be subjecting the sensor to thermal stress unnecessarily. However, if the outdoor temperature is below zero Celsius, you may want to cool down the sensor at a lower temperature to maintain a stable and known temperature value that you can match later when creating dark frames. We do not recommend using the camera with the TE cooler OFF because the camera can get very hot.

To better understand each setting, please consult the pages dedicated to each setting.

## Gain

The gain range of OGMA AP26CC and AP26MC is from 100 to 10000 (don't use comma 10,000 when typing it).

If you are connecting to the camera using APT's native integration or SharpCap with ASCOM, it will be clear the available Gain because these two software show the minimum and maximum values of Gaain that are available.

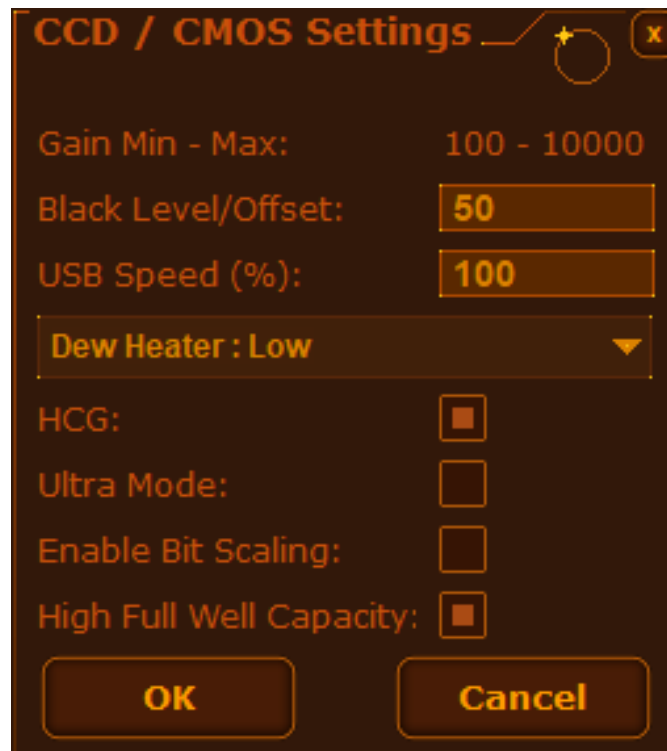

If you are connecting to the camera using the ASCOM driver, it may be confusing that the ASCOM driver GUI shows a Gain range from 0 to 100.



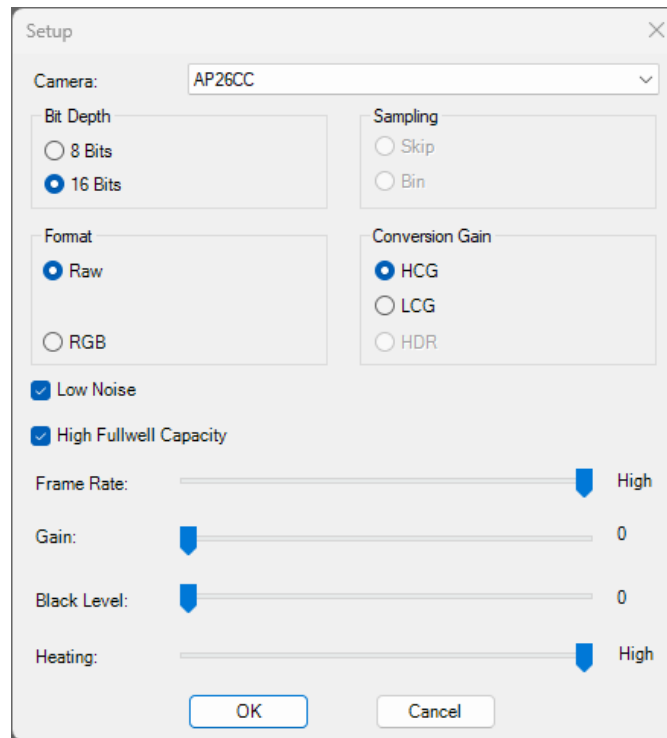

You shouldn't control the Gain through the ASCOM driver GUI; you should always control the Gain from inside your imaging software (e.g. N.I.N.A., APT, etc).

If you use APT through the ASCOM driver and you enter a Gain value below 100, APT will default to 100 (the minimum possible). You will see a log message telling you that the Gain number that you have entered is out of range and that 100 has been selected for you. This is the normal behavior for software that uses ASCOM to connect to the camera.

Please note, the screenshots above are from AP26CC cameras. If your camera model is AP08CC, the controls will differ, and some may be greyed out (unavailable).

## Conversion Gain Switch

OGMA AP26CC and AP26MC support High Conversion Gain (HCG) and Low Conversion Gain (LCG) mode switch.

The Gain ratio between the high and low modes is 3.01.

You will be able to configure this parameter whether you are using our native driver, ASCOM driver, INDI or INDIGO platform.

## Conversion Gain Switch Using ASCOM Driver

Remember that in order to use the ASCOM driver, you will need to download and install our ASCOM driver first.

When using the camera through the ASCOM driver, you can click the configurations of the ASCOM connection to set the desired conversion gain. For astrophotography, we recommend always using the high conversion gain (HCG).

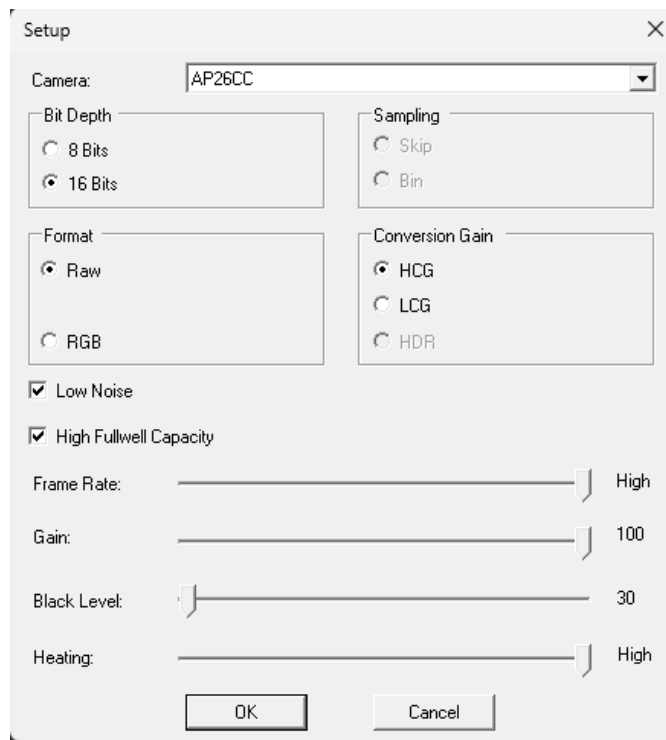

## Conversion Gain Switch Using Native Driver

If you use imaging software such as N.I.N.A. or Astrophotography Tools (APT), you won't need to install a driver as the OGMA cameras are natively integrated into both software.

When using our native driver within an imaging software such as N.I.N.A. and Astrophotography Tools (APT), you will have the opportunity to select High Conversion Gain (HCG) and Low Conversion Gain (LCG) by using a panel or window dedicated to the settings of the camera directly inside the imaging software.

### N.I.N.A.

After selecting and connecting to the OGMA camera, go to Equipment > Camera

Below is a screenshot of the **Camera Settings** panel in N.I.N.A. You can configure the Readout Modes as Low Conversion Gain (LCG) or High Conversion Gain (HCG).

The same panel will let you configure other parameters for your camera in N.I.N.A.

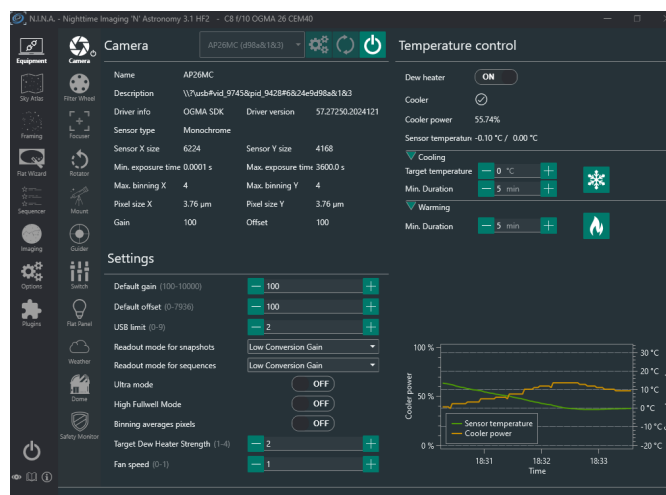

### Astrophotography Tools (APT)

The OGMA cameras are supported natively in APT since version 4.16.

After selecting and connecting to the OGMA camera, click **Settings**. This button is located in the bottom right corner of the main window in APT.

Below is a screenshot of the **Camera Settings** window in APT. You can configure the High Conversion Gain (HCG) and other parameters for your OGMA camera in APT.

## Conversion Gain Switch Using INDI or INDIGO

The INDI and INDIGO platforms are the best choices for connecting to the OGMA cameras if you use MacOS, a Linux-based Operating System, or specialized distributions such as Astroberry and Stellarmate.

### INDI

If you are using Astroberry or Stellarmate, your OGMA driver may be already included. However, if you can't detect the OGMA camera, follow the general procedure for installing a driver in INDI as described below.

If you are using INDI, search for the link to download and install the OGMA camera driver at <https://indilib.org/individuals/devices/cameras>.

Once the INDI driver is installed, select the OGMA camera and look for a Camera Settings panel or window. You can choose High Conversion Gain (HCG) and Low Conversion Gain (LCG).

### INDIGO

The OGMA cameras are supported natively in INDIGO since version 2.0-222. Additionally, the popular imaging software for MacOS, Astroimager, which uses INDIGO, supports the OGMA cameras since version 4.7-755

If you use the INDIGO platform, you don't have to add another driver, as the OGMA cameras are natively integrated into INDIGO.

## Bit Scaling & Bit Depth

The cameras OGMA AP26CC and AP26MC support the bit depths of 8 and 16. You can select which one you want to use.

Bit depth is directly related to the number of colors that an image can have. The higher the bit depth, the more degrees of colours each image can have and, the larger the file size will be.

If you are using the camera through native integration, this setting will be controlled through a checkbox called "Enable Bit Scaling". When this setting is not checked, the camera will use 8 bits. When this setting is checked, the camera will use the maximum bit depth, which happens to be 16 bits for OGMA AP26CC and AP26MC.



APT - Enable Bit Scaling

If you are using the camera through the ASCOM driver, you can select directly whether you want to use 8 bits or 16 bits under "Bit Depth".

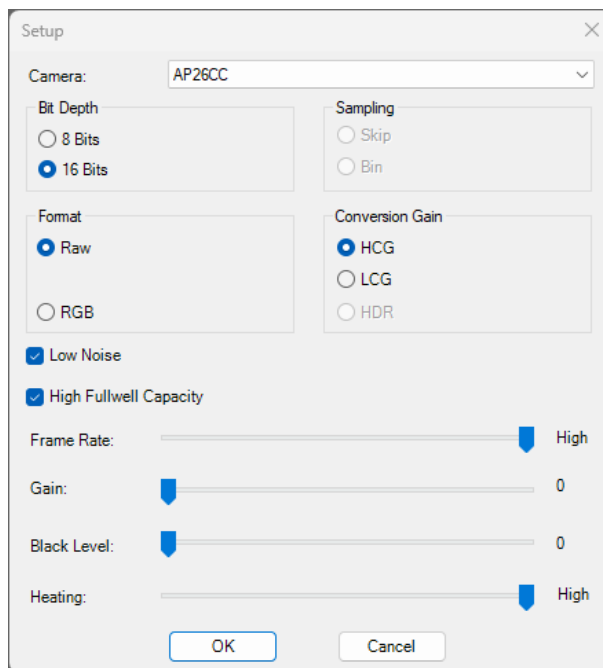

ASCOM - Bit Depth

## Ultra Mode & Low Noise

The Ultra Mode activates a very low read noise mode. Basically, it provides a higher signal to noise ratio, at the expense of a lower frame rate.

If you are using the camera through native integration, this setting will be called "Ultra Mode".

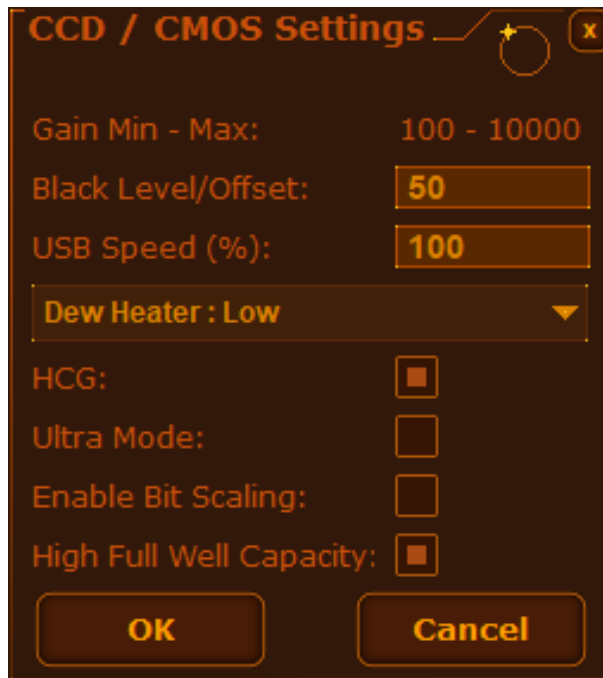

APT - Ultra Mode setting

If you are using the camera through the ASCOM driver, this setting is called "Low Noise".

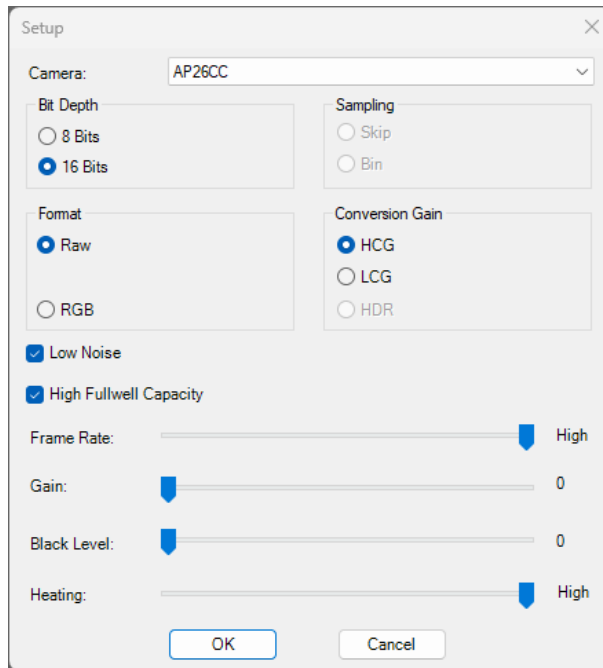

ASCOM - Low Noise mode

## USB Limit

The "USB Limit" setting controls the speed at which your computer acquires images from the camera. This setting is handy for computers that may not be optimally configured, are older, or have slower performance. By limiting the data transfer speed, the setting can help prevent issues like incomplete or lost images that can occur if the computer struggles to handle the full data rate from the camera.

For computers with better performance, we recommend setting the "USB Limit" to the highest value. This allows the camera to utilize the full USB bandwidth, enabling the fastest possible image transfer.

In summary, the "USB Limit" setting ensures reliable image capture, especially on less powerful

computers. If your system can handle it, maximizing the setting will enhance performance.

## Filters

OGMA AP26-series cameras are often sold with a filter kit that includes a Zero Light Leak filter holder and a UV/IR 2" filter.

Since these are full-spectrum cameras that only have an anti-reflections (AR) protective window in front of the sensor, you are required to use a some filter in order to achieve pinpoint stars. This is because different wavelengths of light will focus at a different distance. By using a filter, you are selecting a portion of the spectrum of light that focuses approximately at the same distance.

If you don't use a filter, the stars will have a halo around them.

Depending on whether you own the monochrome or the color version of the OGMA AP26-series cameras, you will have to use a different strategy with your filters.

### **For the Color Astrophotography camera AP26CC**

You should be ready to start imaging from day one by placing the add-on OGMA UV/IR filter inside the OGMA filter holder. Attach one end of the filter holder to the front of the camera, and attach the other to your telescope. Done!

Depending on your optics and its required back focus distance, you may need to place some spacers between the filter holder and the telescope. If this is needed, you would have to acquire separately the spacers that match the diameter of your optics.

If you want to do narrowband imaging to reduce the influence of light pollution or moon light, you can purchase elsewhere a multiband pass narrowband filter or a light pollution filter that cuts down the type of light that's predominant near your location.

### **For the Mono Astrophotography camera AP26MC**

Some will suggest that you purchase an electronic filter wheel. If you have the budget for a filter wheel, you should buy one. If your budget is tight, keep reading because OGMA is on a mission to save you money.

While an electronic filter wheel provides great convenience; it really isn't a requirement for a mono camera as long as you don't mind swapping the filters manually. In fact, owners of RASA telescopes, can't use filter wheels at all.

As mentioned above, OGMA AP26-series cameras are often sold with a filter kit. The OGMA filter holder from this kit can hold any standard 2" filters. The UV/IR 2" filter from this kit is a great luminance filter for monochrome astrophotography.

To start doing color narrowband with a monochrome OGMA camera, only two additional filters are needed: one for Hydrogen Alpha (H-Alpha) and one for Oxygen (OIII). Some reasonably priced 7nm H-Alpha and OIII narrowband 2" can be found at Amazon.

Once your budget grows, you can gradually add the following items to your toolbox:

1. Sulfur (SII) filter
2. RGB filters

3. Electronic filter wheel (to swap filters automatically)

## Firmware Updates

Learn how to update the firmware of your OGMA AP series of cameras.

[Firmware update for OGMA cameras AP08CC only](#)

## Firmware Update for AP08CC

### Introduction

All OGMA cameras of model AP08CC sold before February 12, 2025, will require this update.

If you bought your AP08CC after February 12, 2025, your camera already has the latest firmware, 4.49.

**Note:** It is possible that after updating the camera's firmware, you will need to update the Ogma DLL file inside the installation directory of software like N.I.N.A. This won't be necessary after N.I.N.A. releases its Version 3.2 or after your software adopts the latest version of our SDK. If you are using N.I.N.A. Version 3.1, you may follow the instructions to [replace the OGMA DLL file](#). If you are using the camera through ASCOM, installing the latest version of [our ASCOM driver](#) is recommended.

### Files

[AP08CC-FPGA4.49\\_UPDATE.zip](#) - Upgrade tool and firmware - February 12, 2025.

### Requirements

To apply this update to your camera, you will need:

1. A Microsoft Windows 10 or 11 computer.
2. A camera model, AP08CC that hasn't received this update.
3. The decompressed content of the ZIP file downloaded from this page.

### Steps to Update the Firmware

1. Connect one extreme of the USB cable to the camera and the other extreme to a blue USB 3.0 port on your Windows computer.
2. Connect the power cable and ensure the camera is constantly powered during the update.



3. Double-click the file **updatefw.exe**. You will see a window asking you to select the camera.

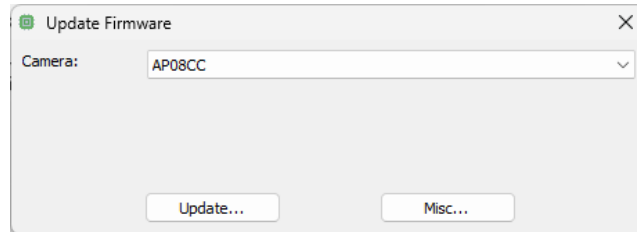

4. Select the camera that shows as "**AP08CC**". If you only have one camera connected, this should be the only option available, and it will be selected by default. We recommend connecting only one camera to your computer during this process to avoid mistakes.
5. Before installing the new firmware, identify the version that is currently installed. To do so, click [Misc...] > [About...]

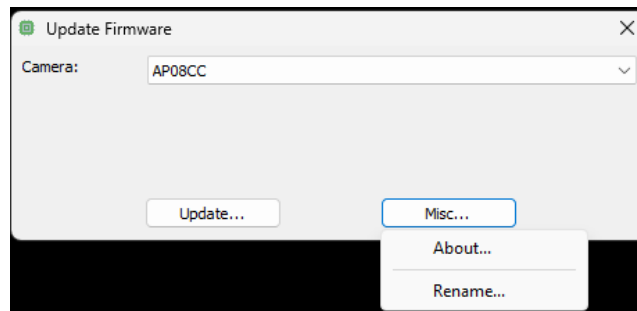

6. Please note that the **FPGA value** listed should be older than the one you are applying. Click [OK] to close the version window.
7. Click [Update...], and a window will open to select the appropriate firmware.
8. Select the firmware that you want to apply.  
**Remember:**
  - The filename should contain your camera model.
  - Apply only a newer update, as determined by the FPGA number.
9. A confirmation window will pop up. If everything looks OK, click [OK]
10. Wait until the update is completed. At the end, you will see a confirmation.
11. **IMPORTANT:** After you see the confirmation of a successful update, power off the camera.

## Video Tutorial



## Thin Horizontal Bands

This video shows the steps to upgrade the camera's firmware from version 4.35 to 4.36. The process is similar for other versions; the only difference is the version number.

### Known Issues & Tips (AP Cameras Series)

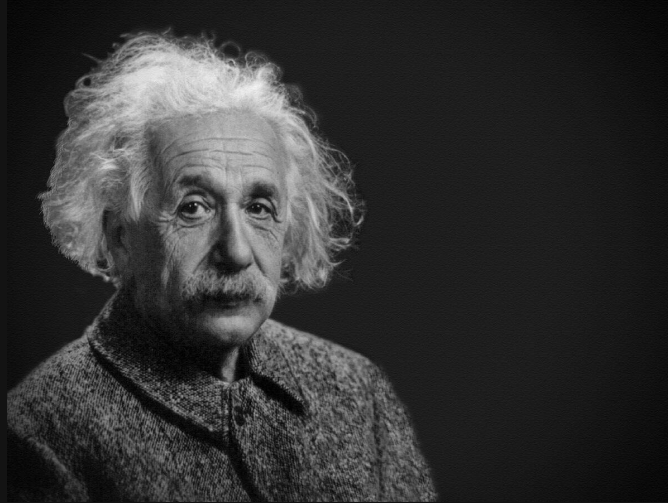

*"Anyone who has never made a mistake has never tried anything new."*

— **Albert Einstein**

At OGMA, we believe in full transparency with our customers. No matter how advanced, every product may encounter issues, and we are committed to openly addressing them. Our "Known Issues" section acknowledges these challenges and provides solutions and updates. This openness helps us improve continuously and ensures you receive the best possible experience with our products. Unlike some that might hide problems, we prefer to face them head-on and use your feedback to enhance our offerings.

### Thin Horizontal Bands - Rolling Shutter Noise

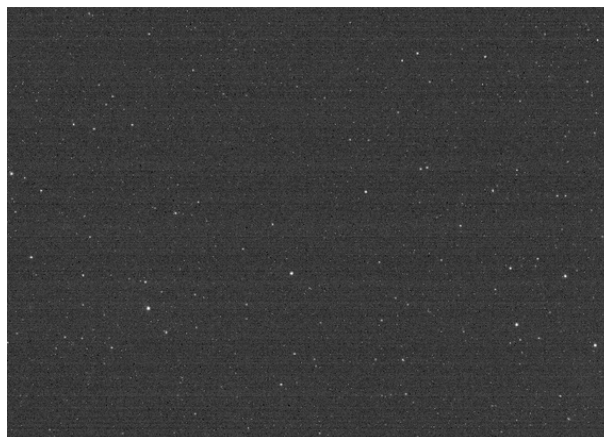

You may see thin horizontal bands when an image's histogram is stretched. Note that some astronomy software will show preview images that are automatically stretched. This shouldn't affect the final result.

A highly sensitive image sensor with a **rolling shutter** will likely have some banding in its raw data. What you are observing is a few photons that excited a few electrons. Enjoy the show! You are watching quantum physics playing games with a rolling shutter.

This isn't related to a particular camera brand. SharpCap previously introduced a setting in their software to mitigate banding. See the screenshot in their documentation at <https://docs.sharpcap.co.uk/4.0/#!2!Pre-processing>.

You may only see this banding from some camera brands because some manufacturers may mitigate banding through firmware or drivers. The risk of doing this is that faint stars and nebula may be "mitigated," too.

We have seen reports online about these thin bands on cameras from different manufacturers before the issue has been "corrected" by firmware or driver updates.

This type of rolling shutter noise is more pronounced when using narrowband filters because sometimes there is insufficient data to saturate the sensor.

Here are a few suggestions to reduce the rolling shutter noise:

- Try a different conversion mode: Use HCG instead of LCG.
- Increase the Offset: 100, 500, 1000
- Always use dithering
- Always use calibration frames for processing your images; this, combined with dithering, will help remove the banding noise while protecting the faint stars and nebula in your images.

## **Dead Pixels / Hot Pixels / Warm Pixels**

### **Dead pixels:**

All sensors have dead pixels; it's the nature of the manufacturing process. All IMX sensors used in astrophotography are manufactured by SONY according to their standard specifications.

Some camera manufacturers include ways of erasing dead pixels or hot pixels in their firmware. Some call this process DPS technology (Dead Pixel Suppression). The risk of erasing these pixels inside the camera is that tiny stars can be erased, too.

Some gain modes are more prone to showing dead pixels or warm pixels. For example, the HDR mode in some of our cameras outputs the data as raw as possible.

### **Hot and Warm pixels:**

These are individual pixels on a digital camera sensor stuck at a higher brightness level. This happens with most camera sensors and are most noticeable in images with very long exposure times or very high ISO settings. These pixels can appear as bright spots in an image and may be mistaken for small stars or hot pixels in preprocessing.

One of our customers suggested that those using Pixinsight to process their images can try removing the hot/warm pixels using hot-sigma rejection (3.0 to 4.0) with Cosmetic Correction before debayering. This should help solve potential problems with star registration and alignment later. It may be possible to do the same with other software.

### **In general:**

We believe the best way to control these sensor imperfections is through dithering during image

capture and dark frames during post-processing. Dithering and dark frames are two things that you will be using in astrophotography anyway.

## Very Wide Horizontal Bands in N.I.N.A.

When using the camera with N.I.N.A. version 2.2, a wide horizontal band may appear randomly in some sub-exposures. This only happens sometimes and may never happen because it depends on the CPU type of the computer controlling the camera.

A fix has been added to version 3.0 of N.I.N.A., which is currently only available as a nightly build. Since nightly builds are not recommended for everyday use, you can fix this issue temporarily by replacing the file `ogmacam.dll` inside your installation of N.I.N.A. version 2.2 with a copy of the same file that contains the fix.

To do so:

1. Download one of the following files depending on whether your operative system is x64 or x86:
  1. [ogmacam.dll](#) (x64 version)
  2. [ogmacam.dll](#) (x86 version)
2. Copy the `ogmacam.dll` file and paste it into the N.I.N.A. installation directory, which may be one of the following:
  1. `C:\Program Files\N.I.N.A. - Nighttime Imaging 'N' Astronomy\External\x64\OGMA\` , or
  2. `C:\Program Files\N.I.N.A. - Nighttime Imaging 'N' Astronomy\External\x86\OGMA\`
3. Click Yes to confirm replacing the existing file with the same name.

Once N.I.N.A. version 3.0 becomes the recommended version, you can upgrade as usual, and this file will be replaced by the one that comes with N.I.N.A.

## Adding the Latest OGMA Cameras to INDI

The camera model AP08CC was integrated into INDI v2.0.5. You don't need to worry about doing this if you have INDI Library v2.0.5 or newer.

Other models of OGMA cameras, such as the guide/planetary cameras GP662C, GP678C, and GP678M, are currently being integrated into INDI. If you would like to use these newer models before they are integrated with INDI, replace the file `libogmacam.so` in your INDI installation directory with the latest version from our SDK.

To do so:

1. Create a backup of your current `libogmacam.so` file by renaming it to `libogmacam.so_bak`.
2. Download one of the following files depending on whether your operative system is x64 or x86:
  1. [libogmacam.so](#) (x64 version)
  2. [libogmacam.so](#) (x86 version)
3. Copy the `libogmacam.so` file and paste it into the INDI installation directory `/usr/lib/x86_64-linux-gnu`
4. Click Yes to confirm replacing the existing file with the same name.

Once the next version of the INDI Library is released, this file will be replaced, and you won't need to apply this fix.

## INDI Couldn't Connect

In some Linux systems running the INDI platform, the user running the program doesn't have the necessary file permission to send configurations or commands to the camera.

This manifests as a software freeze when you try to start the fan or TE cooler, or a being unable to instruct the camera to take a photo.

Before trying anything, you should update to the latest version of INDI.

### If updating your system doesn't solve the problem, try the following:

1- Identify the USB ID of your camera

Open the Linux terminal and type:

```
lsusb
```

You will see something like this:

```
Bus 002 Device 005: ID 9745:93da TP AP26CC
```

This tells you that the camera AP26CC is connected with the ID = 9745.

2- Verify that INDI expects the same device ID.

As an administrator, edit your local file `/usr/lib/udev/rules.d/99-ogmacam.rules` and make sure the value of `ATTRS{idVendor}` is:

```
ATTRS{idVendor}=="9745"
```

After saving this change, unplug the camera, exit all INDI software, and reconnect.

At this point, the camera should work well.

## Weird Cooling Process

Under certain conditions, the cooling graph looks weird. Temperature rises, and cooling power rises at the beginning.

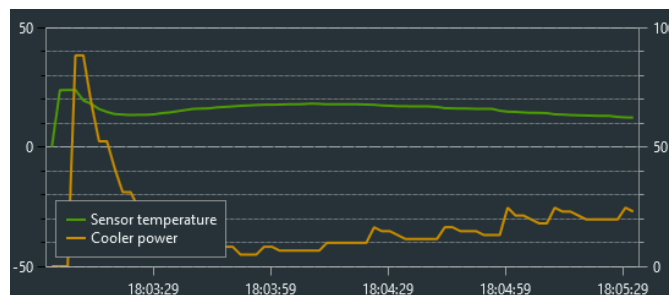

The logic of the cooling process is controlled by the software you use to control the camera; this is not a behavior of the camera itself.

During our tests, we have observed that this happens sometimes after a camera is accidentally unplugged or the software is turned off without disconnecting the camera using the "Disconnect" button in the software. When this happens, it is possible that on the next connection, the software still uses the last temperature measurement to initiate the cooling routine.

To correct this, try to restore everything to a clean state by using the disconnect button, shutting down the software, and unplugging the camera, in this order. When done, reconnect everything in the opposite order.

## Help Us Improve

While we strive to ensure that our products meet the highest standards, occasionally, some issues may arise that we have not yet documented. We highly encourage you to [let us know](#) if you encounter any problems that are not listed on our known issues page.

Additionally, if you've discovered a workaround or a solution to an issue you've experienced, [we would love to hear about it!](#) Sharing your solutions can greatly assist other users facing similar challenges.

Your insights could lead to direct improvements in our manuals and troubleshooting guides.

We are looking forward to your input!